

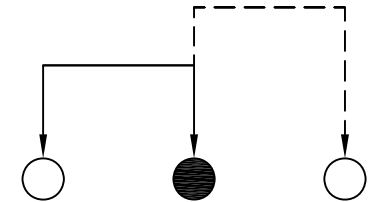

CAD FILE:

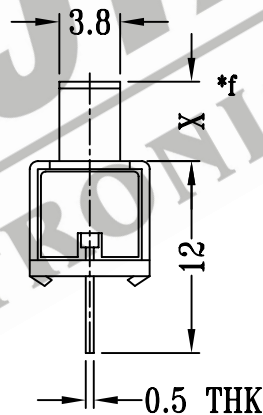

SCHEMATIC (NON-SHORTING)

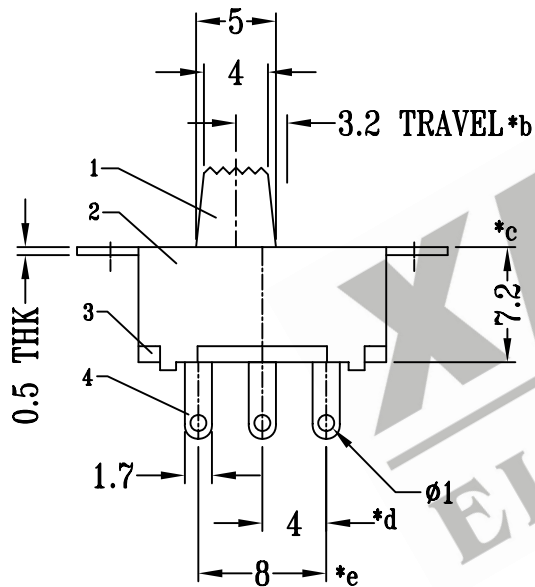
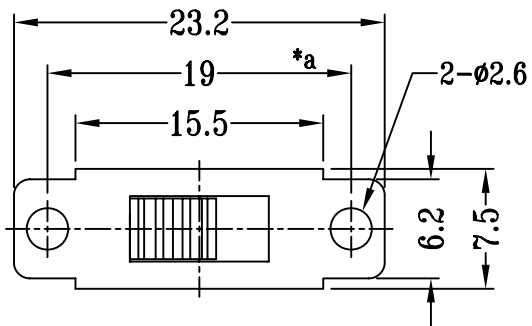
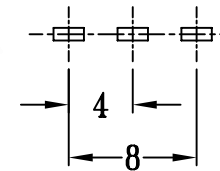

P.C.B LAYOUT

注:带"\*"表示关键尺寸(6个)

8					TOLERANCE UNLESS SPECIFIED	SHENZHEN XIEJIA ELECTRONICS CO.,LTD.				
7										
6	CONTACT CLIP	COPPER STRIP	1	Ag PLATED	WITHIN: 1.5±0.1mm OVER : 1.5±0.2mm	ISSUE	DATE	DESCRIPTIONS OF REVISION		APPD.
5	SPRING	STEEL WIRE	1	TEMPER						
4	TERMINAL	BRASS STRIP	3	Ag PLATED OVER Ni PLATED	TITLE : VERTICAL SLIDE SWITCH	UNIT : mm	DRWG NO.: XJ-DR-SS12F85-00			
3	BASE	PHENOLIC RESIN	1	NATURAL						
2	FRAME	STEEL STRIP	1	Ni PLATED	MODEL: SS-12F85	SCALE: 2 : 1	DWN.	ZHOUYU	2002-4-15	
1	KNOB	POM	1	BLACK			CHK'D	FANGYING	2002-4-15	
NO.	PARTS	MATERIALS	Q'TY	FINISH	ALL MATERIALS MUST BE COMPLIANT TO ROHS			APPD.	KANGXINAN	2002-4-15